



true

ALADDIN

Leonardo Rossano

ALADDIN

Leonardo Rossano

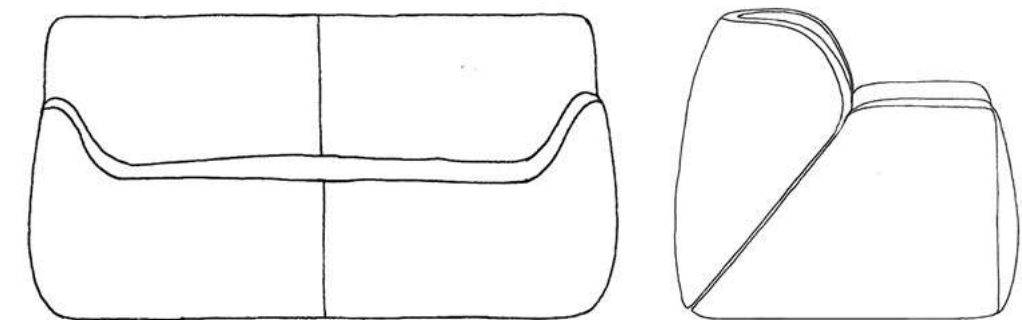

Aladdin è il confortevole sistema di poltrone e divani caratterizzato da forme sinuose ed avvolgenti; è stato ideato per gli spazi pubblici destinati all'attesa e al relax.

La sapiente manifattura artigianale contribuisce alla creazione di un divano dall'aspetto intrigante, indicato per zone informali di riposo anche in ambiti domestici.

Aladdin is the comfortable seating system characterized by sinuous and embracing shapes, it's made for waiting areas and relaxing public spaces.

The skillful handcrafted production contributes to the creation of an intriguing sofa, perfect for informal spaces, both public or domestic.





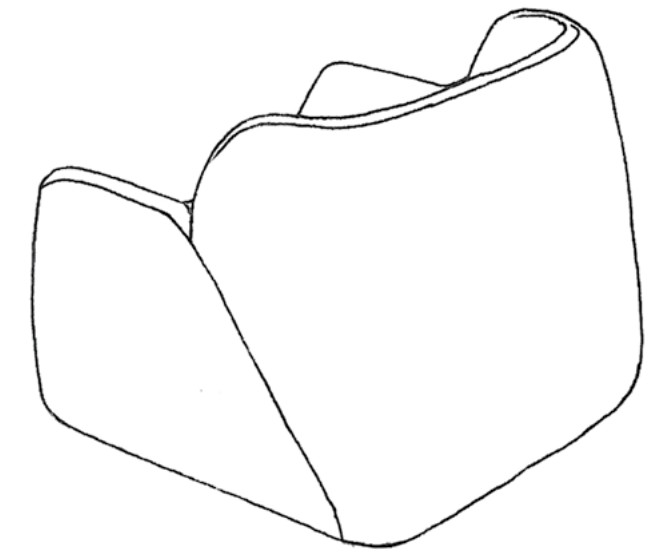

AL 1000

poltrona • armchair

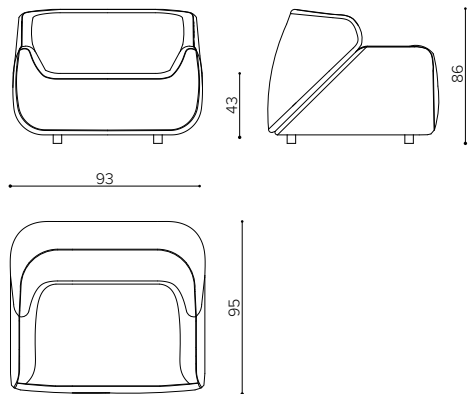
**AL 2000**

divano 2 posti • 2 seater sofa

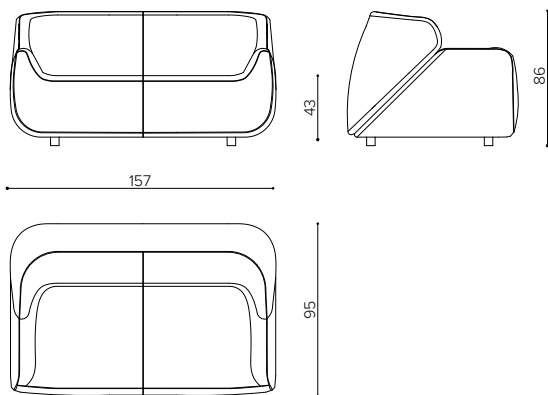
**AL 3000**

divano 3 posti • 3 seater sofa

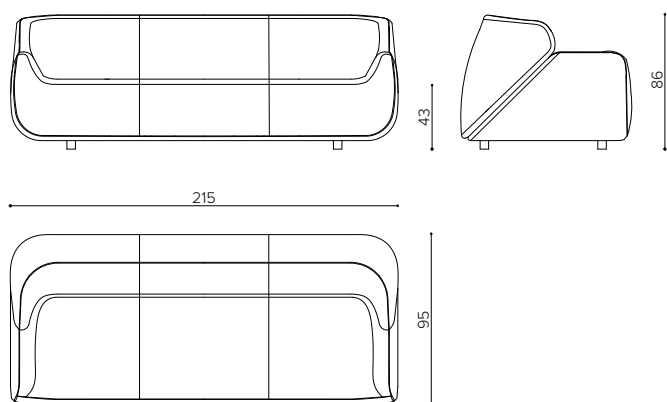

Direzione Artistica	Aldo Parisotto
Fotografia	Dario Breggiè
Progetto grafico	Antitetico
Progetto realizzato da	TRUE Design s.r.l.

true

TRUE DESIGN s.r.l.
Via Leonardo da Vinci 2
35040 S.Elena (PD) ITALY
t (+39) 0429 692483
f (+39) 0429 668018
info@truedesign.it
www.truedesign.it

sede legale/fatturazione
V.le della Repubblica 8
35043 Monselice (PD)
P.IVA C.F. 04428190286

Arca

Orlandini Design



true

Creata dalla matita dello studio Orlandini Design, Arca rappresenta una declinazione completa del concetto di poltrona per spazi attesa e lounge, proponendosi in 3 differenti altezze di schienale abbinabili a numerose tipologie di basamenti, tra cui la nuova base in legno a dondolo. La versione standard con schienale basso è ideale per ambienti attesa veloci, o per grandi meeting rooms, mentre la variante con schienalino aggiunto dona maggiore importanza e comfort alla seduta. Arca trova infine la sua declinazione più caratterizzante con lo schienale alto, avvolgente, ma non invadente, per una pausa in completo relax. Arca ricalca alla perfezione l'attuale concetto di "Smart Lounge", in cui l'attesa diventa un momento di riflessione, lavoro o semplice relax sul web; tutte le versioni di Arca sono pertanto accessoriabili con una tavoletta di appoggio, dalle dimensioni generose, installata su un meccanismo di rotazione.



Coming from Studio Orlandini's inspiration, Arca defines a new concept of armchair for lounges and waiting areas, available in 3 backrest heights, which can be combined to many base typologies. The standard option, with low backrest, is ideal for quick waiting areas, large meeting rooms, while the medium back option, with backrest cushion, gives more prestige and comfort to the armchair. The High version gives the unique touch of design to this collection, with its embracing backrest for a break of full relax. Arca perfectly traces the new concept of "Smart Lounge", where waiting moments become great occasions for reflection, working or relaxing on the web; all versions of Arca can indeed be equipped with a large writing tablet, swivel around the arm.



















true







VARIANTS
Varianti

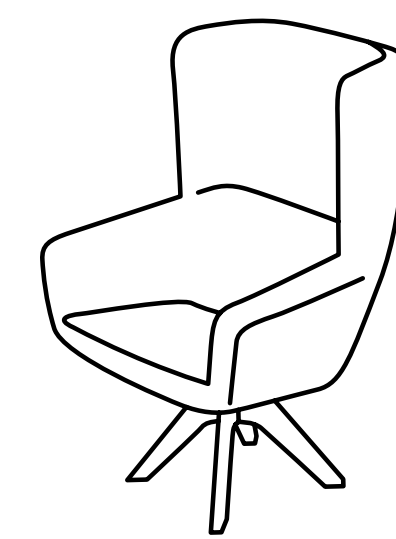

AA 9099
W76 · D78 · H123

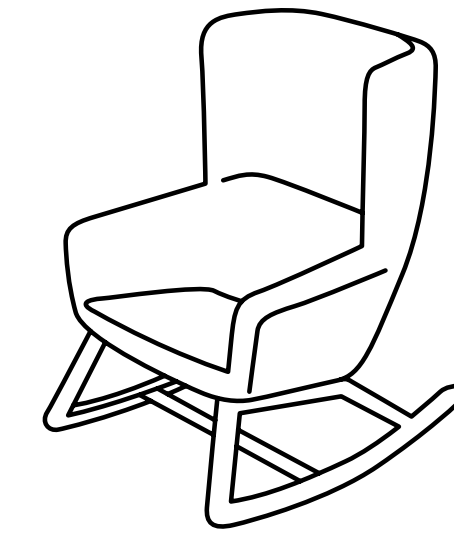

AA 909R
W76 · D95 · H117

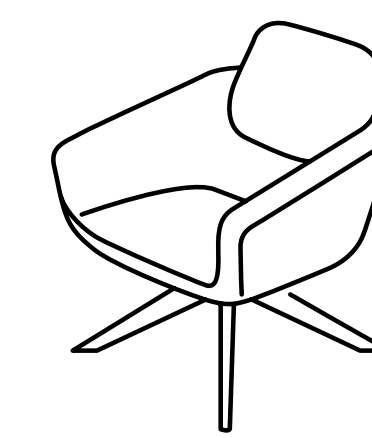

AA 8090
W76 · D73 · H88

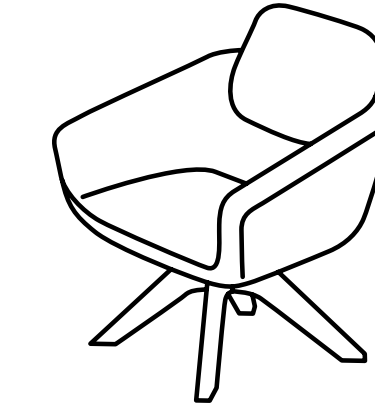

AA 8099
W76 · D73 · H88

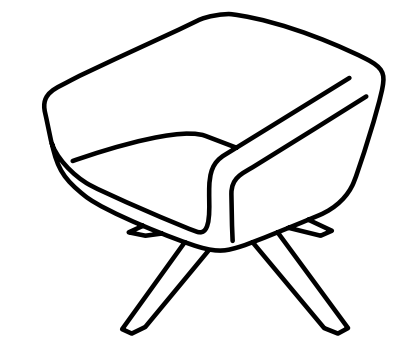

AL 7090
W76 · D70 · H73

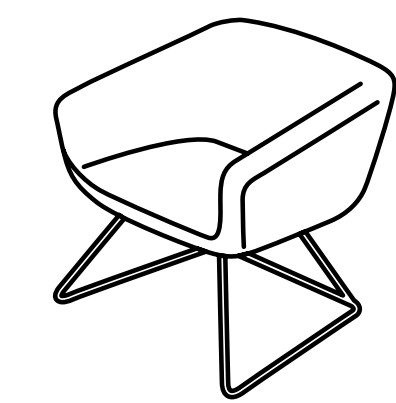

AA 709S
W76 · D70 · H73

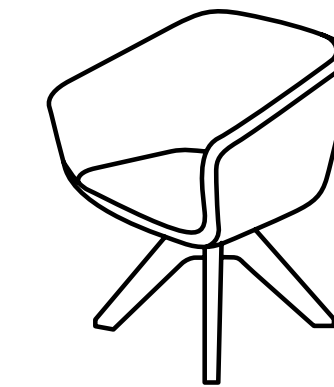

AA 5095
W62 · D56 · H79



AA 5099
W62 · D56 · H79

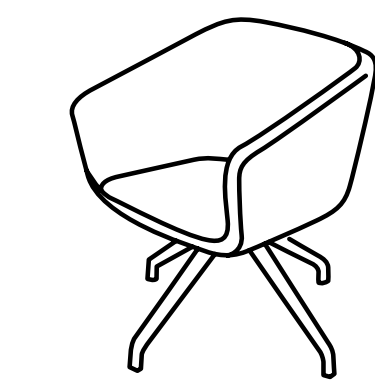

AA 4096
W56 · D54 · H71

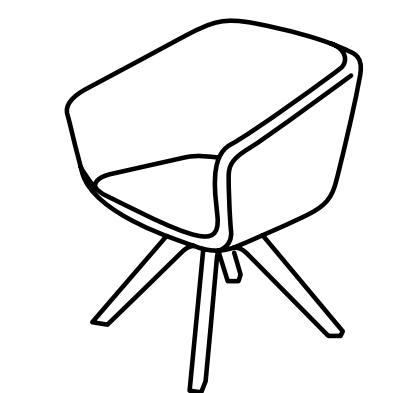

AA 4094
W56 · D54 · H71

true

True Design s.r.l.

Via Leonardo Da Vinci 2 - 35040 Sant'Elena (PD) Italy
Tel. +39 0429 692483 - info@truedesign.it - www.truedesign.it

Clara

Parisotto+Formenton



true



Collection of seats composed by armchair, sofa and dormeuse, defined by sinuous shapes. Clara embraces the person seated thanks to a comfortable element working as backrest and armrest. Its pronounced asymmetry emerges as the main aesthetic feature in this piece of furniture of classic inspiration but of modern design. A comfortable seat, relaxing and informal alongside its rounded shapes.

Piccola collezione di sedute, composta da poltroncina, divano e dormeuse, caratterizzata da forme avvolgenti. Clara abbraccia l'utilizzatore grazie ad un accogliente elemento che funge da schienale e bracciolo. La sua marcata asimmetria emerge come la maggiore connotazione estetica di un arredo di ispirazione classica, ma di taglio contemporaneo, che vuole evidenziare al primo sguardo l'invito ad una seduta confortevole, rilassata ed informale tra le sue curve.





















VARIANTS
Varianti

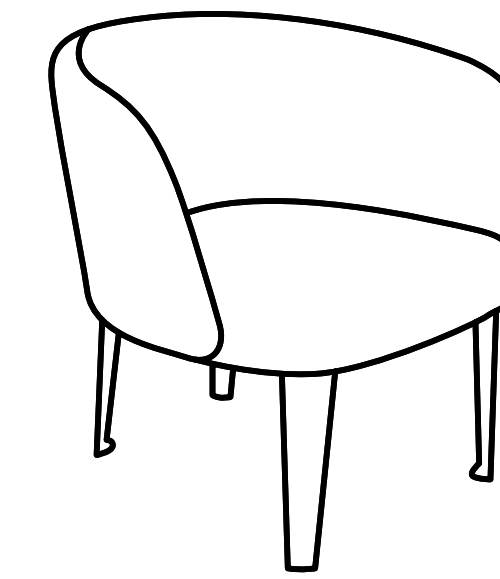

CL 100L
W65 · D66 · H70

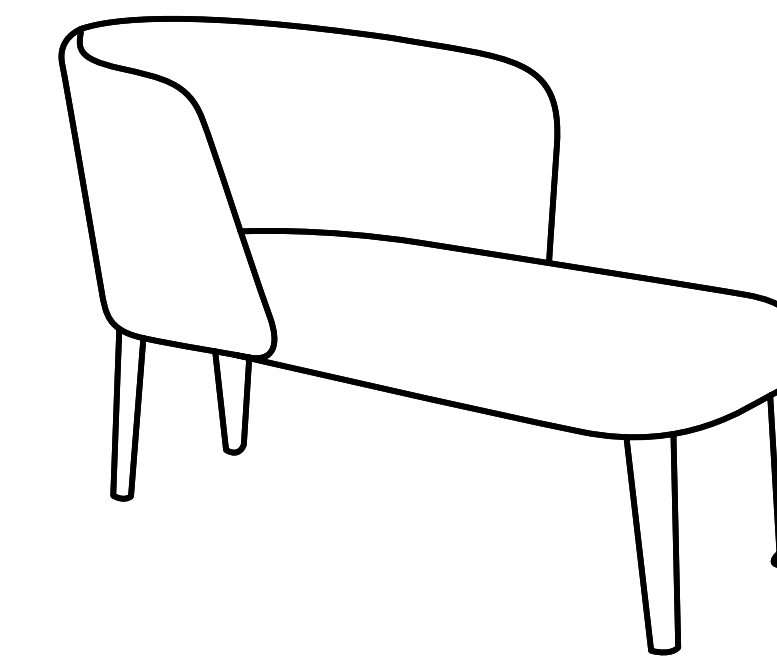

CL 200L
W120 · D66 · H70

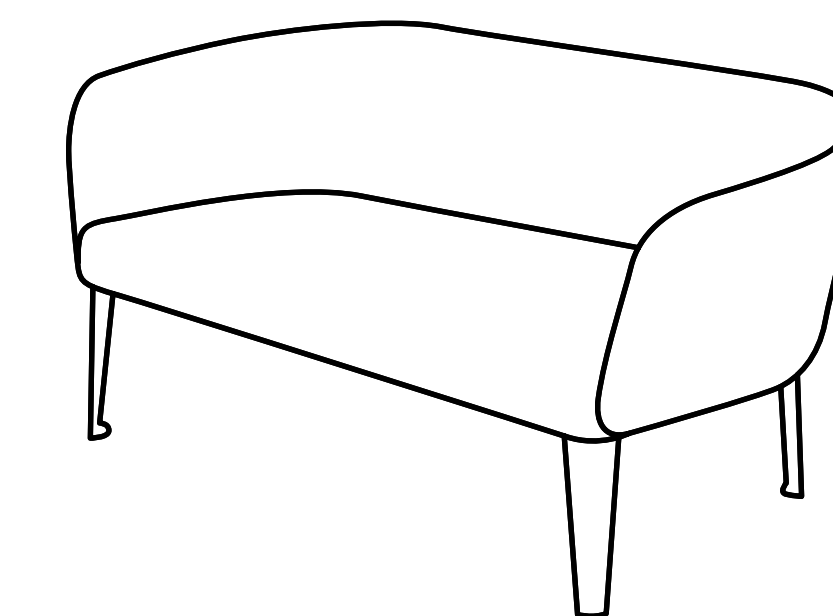

CL 3000
W146 · D66 · H70

true

True Design s.r.l.

Via Leonardo Da Vinci 2 - 35040 Sant'Elena (PD) Italy
Tel. +39 0429 692483 - info@truedesign.it - www.truedesign.it

DNA

Leonardo Rossano & Debora Mansur



true



Inspired by the dynamic forms of biogenetics, the DNA modular bench consists of a single element of curved wood plywood, assembled specularly.

The result is an appealing piece of furniture with a particular helix shape, each step of which corresponds to a seat suitably separated from the others. DNA is also available in a version upholstered in leather or fabric. Thanks to its adaptability and sturdy craftsmanship, DNA is the perfect addition for hospitality settings like lobbies, lounges and guestrooms. DNA is also available in the upholstered collection, in fabric or leather.

Ispirata dalle forme dinamiche della biogenetica, la panca modulare DNA consiste in un singolo elemento in compensato di legno curvato, assemblato specularmente.

Il risultato è un avvolgente elemento d'arredo dalla particolare forma ad elica, ad ogni passo della quale corrisponde una seduta opportunamente separata dalle altre. Grazie alla sua versatilità e alla sua robustezza artigianale, DNA è l'aggiunta perfetta per ambienti di hospitality come lobby, lounge e sale d'attesa.

DNA è disponibile anche nella versione rivestita in pelle o tessuto.











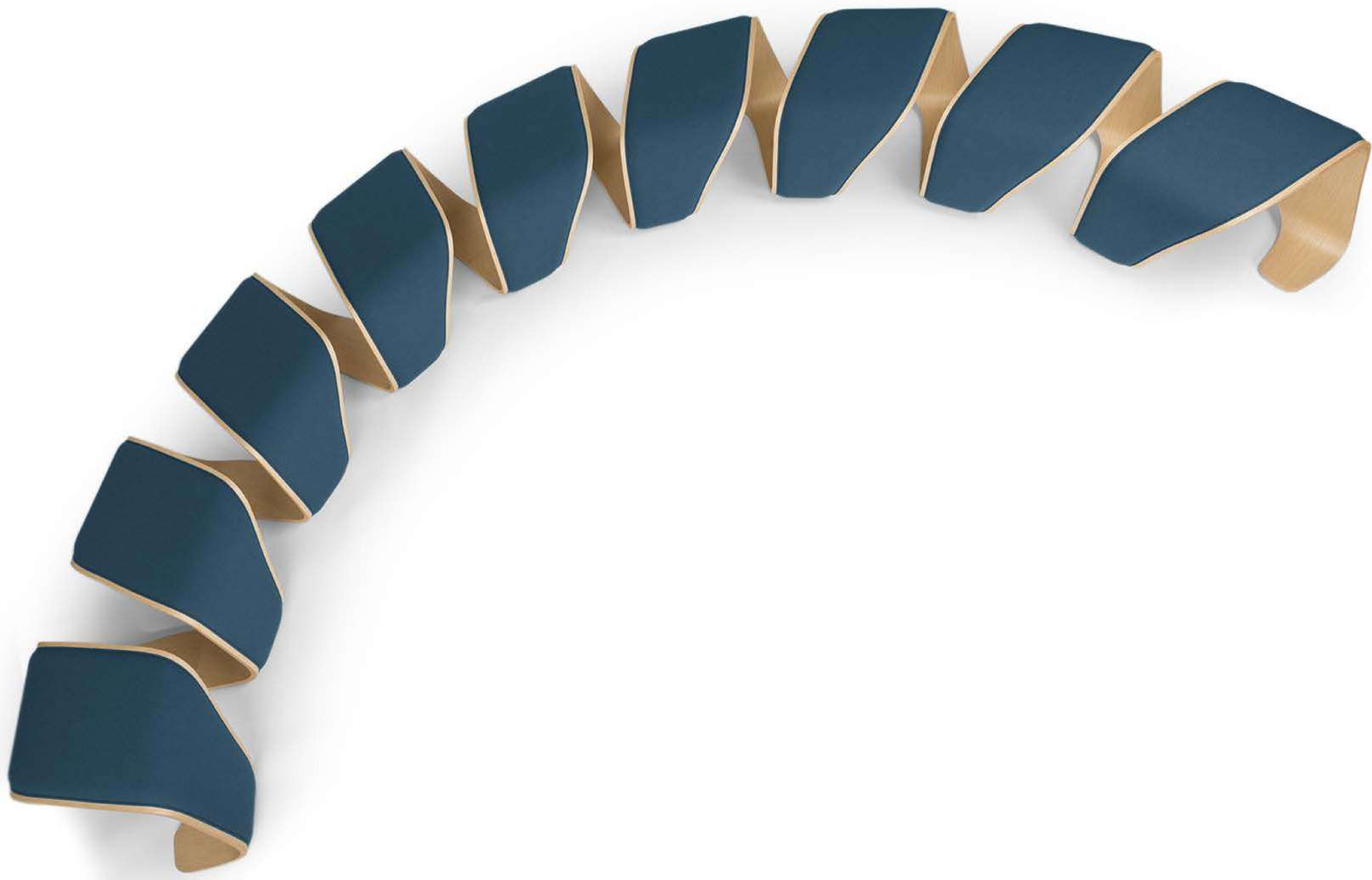



VARIANTS
Varianti

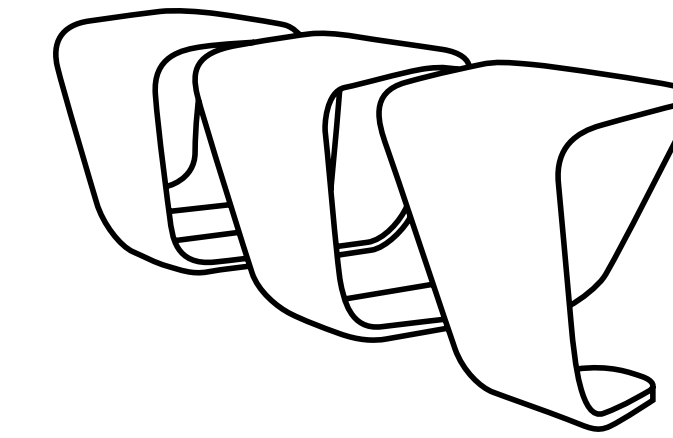

DN 3000
W170 · D48 · H46

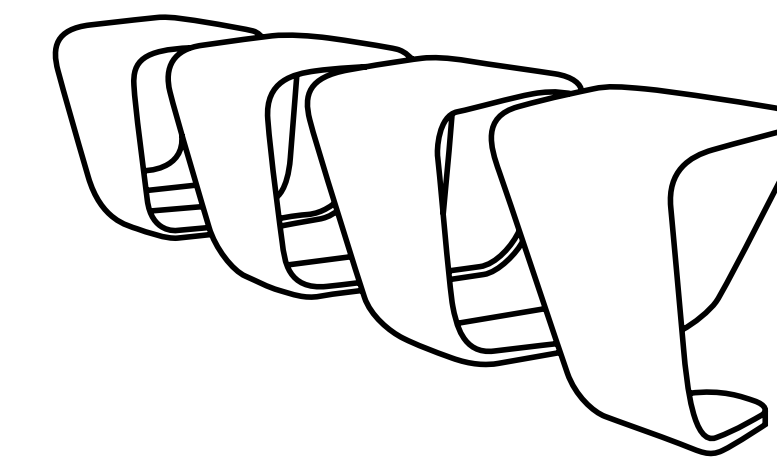

DN 4000
W225 · D48 · H46

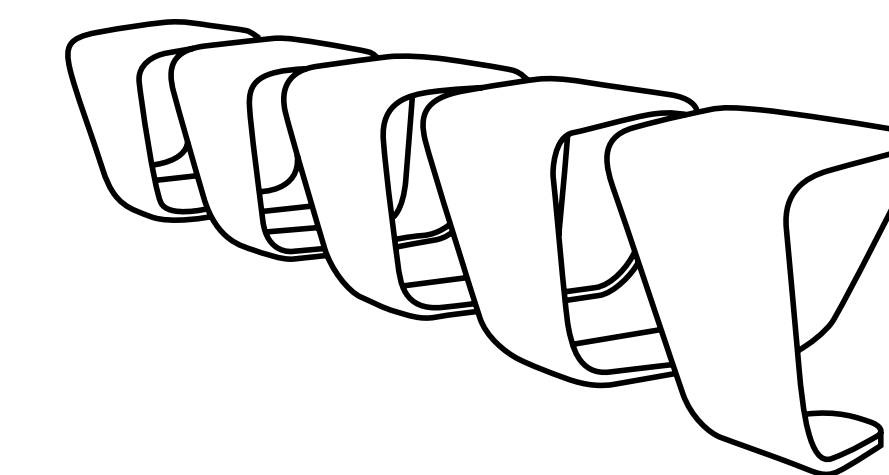

DN 5000
W280 · D48 · H46

true

True Design s.r.l.

Via Leonardo Da Vinci 2 - 35040 Sant'Elena (PD) Italy
Tel. +39 0429 692483 - info@truedesign.it - www.truedesign.it

Grillo

Parisotto+Formenton

true





Lounge armchair with curved wooden frame.

Grillo is defined by the contrast between the structure, the paws, dynamic and characterized by stretched curves and counterposed arches, gathering with the seat in between, juxtaposed.

The thermo curved wooden element, without ever changing its section but only through calibrated torsions, creates the foot, the armrest and the backrest as a unique line moving through the space.

The contrast between the colors and the materials is the main aesthetic feature of this collection.

Poltroncina lounge con struttura in legno curvato.

Grillo è caratterizzato dal contrasto tra la struttura, le zampe, dinamica e caratterizzata da curve tese ed archi contrapposti che si incontrano e la seduta che vi si inserisce come giustapposta.

Il nastro in lamellare termocurvato, senza mai cambiare la propria sezione ma solo attraverso delle calibrate torsioni, crea in continuità prima il piede, poi il bracciolo e lo schienale come un unico segno che si muove nello spazio.

Grande valenza estetica ha il contrasto, con cui si può giocare, tra il colore e la caratterizzazione materica degli elementi in legno e di quelli imbottiti.

















VARIANTS
Varianti

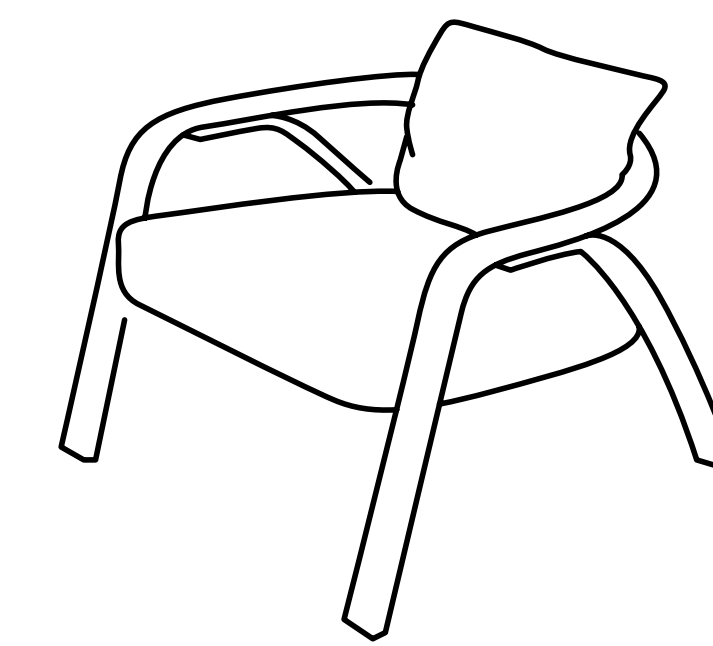

GR 1000
W80 · D81 · H66

true

True Design s.r.l.

Via Leonardo Da Vinci 2 - 35040 Sant'Elena (PD) Italy
Tel. +39 0429 692483 - info@truedesign.it - www.truedesign.it

Hive

Favaretto & Partners



true

Hive represents the synthesis of the armchair in the executive environment, with a full collection of rotating chairs for the office and solid wood armchairs for meeting tables or waiting areas. The rigorous shapes get along with the stitching, endorsing the design.

Hive rappresenta la sintesi della poltrona nello spazio direzionale, proponendo una collezione completa di sedute girevoli per ufficio e poltrone per tavoli riunioni e ambienti d'attesa caratterizzate dalla struttura in legno massello. Le forme rigorose sono armonizzate dalle cuciture che ne valorizzano il design.















VARIANTS
Varianti

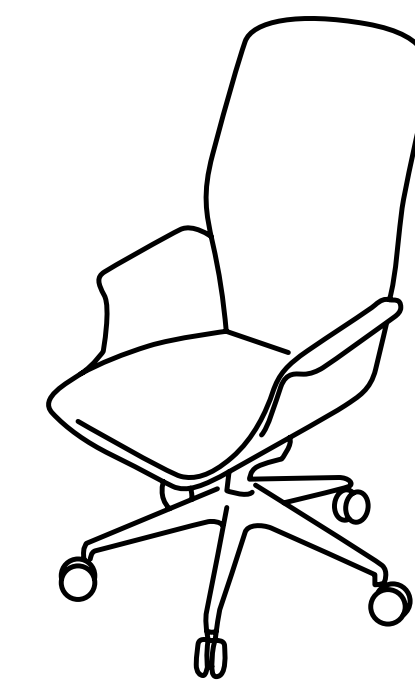

HV 9798
W66 · D60 · H119-127

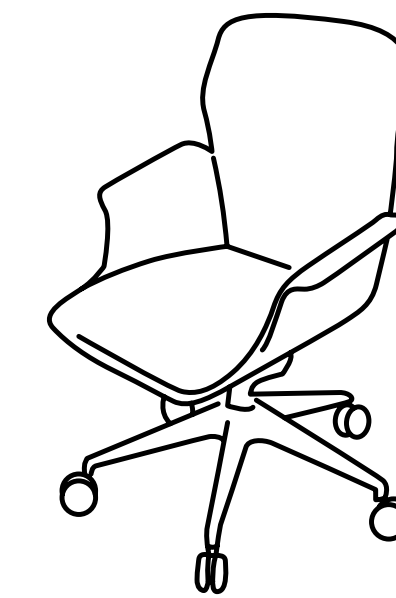

HV 8098
W66 · D60 · H108-116

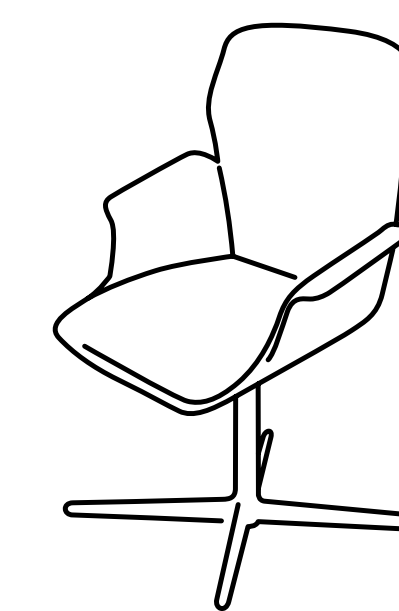

HV 4098
W63 · D63 · H77-90

true

True Design s.r.l.

Via Leonardo Da Vinci 2 - 35040 Sant'Elena (PD) Italy
Tel. +39 0429 692483 - info@truedesign.it - www.truedesign.it

Millepiedi

Parisotto+Formenton



true



Millepiedi is characterized by a modern and minimal design and develops a concept of functionality and flexibility in a wide range of configurations and dimensions. The contemporary design develops in a wide range of configurations and dimensions a conceptual idea based on functionality and flexibility, combined with high end details. The importance of the quality is translated into a vibrant union of design and craftsmanship experience, enhanced by a constant research in details and finishings.

Il design contemporaneo ed essenziale di questo sistema di sedute declina in svariate configurazioni un'idea concettuale di funzionalità e flessibilità, coniugata con un'estetica fatta di dettagli curatissimi. Il valore della qualità è tradotto in connubio vibrante e continuo tra pensiero progettuale e sapienza manifatturiera, ricerca nei dettagli e nelle finiture.



true





true











VARIANTS
Varianti

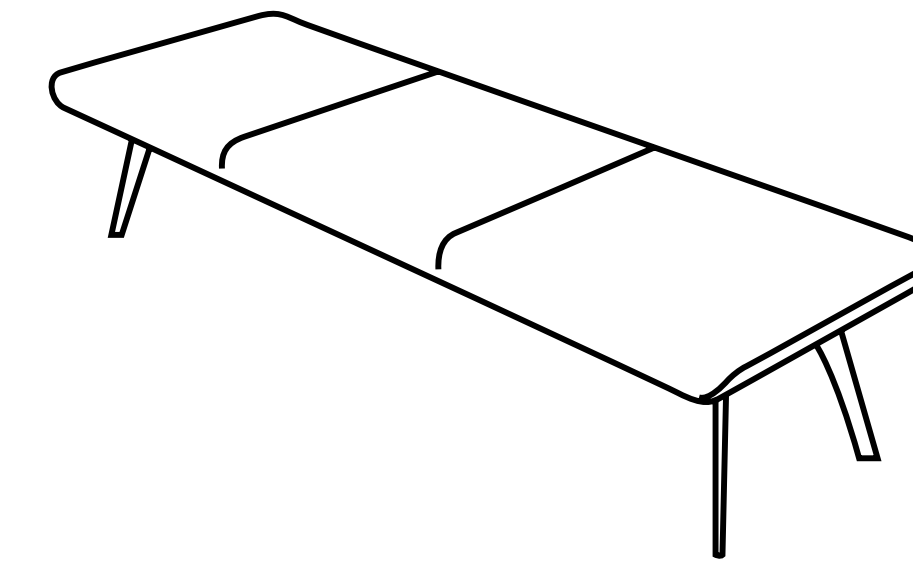

MP 3000
W180 · D58 · H43

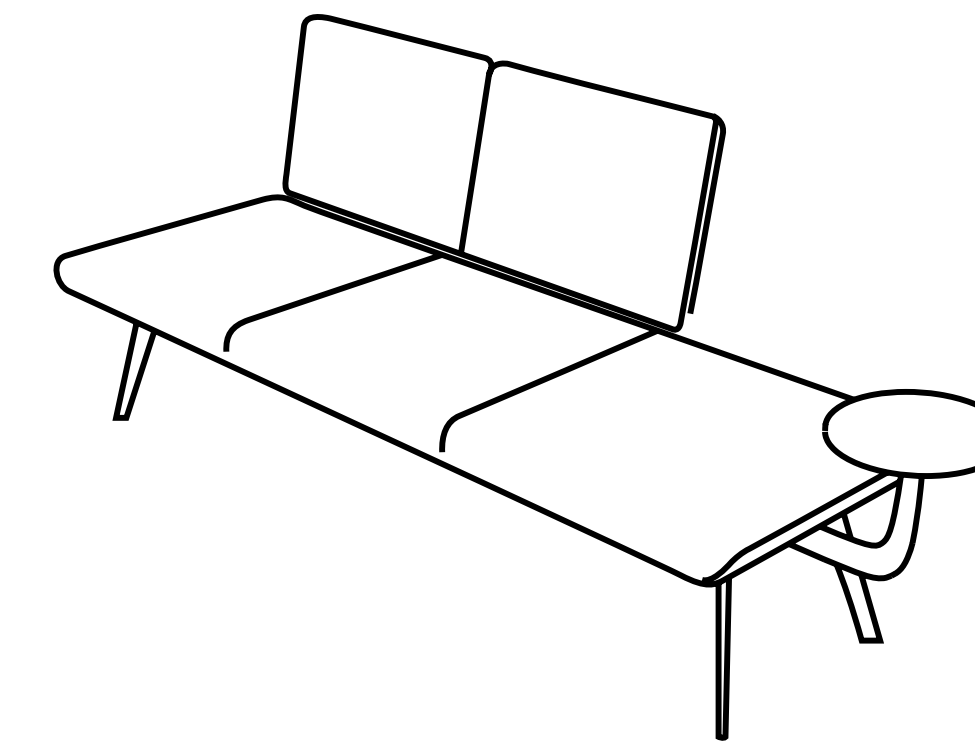

MP 3000 + MP 2200W
W200 · D65 · H83

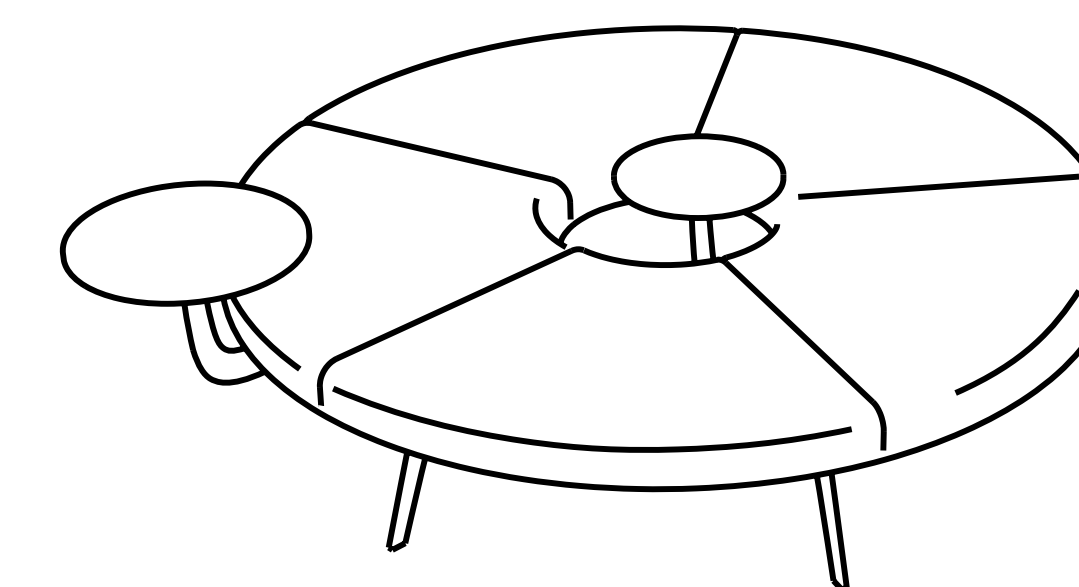

MP 5P0R
Ø156 · D180 · H40

true

True Design s.r.l.

Via Leonardo Da Vinci 2 - 35040 Sant'Elena (PD) Italy
Tel. +39 0429 692483 - info@truedesign.it - www.truedesign.it

Not
E-ggs Design



true



A wide shell embraces the seat in a warm embrace.

The seams define the soft lines, giving it an elegant and versatile look. Suitable for conference hall and relax spaces of hotel and domestic environment.

The NOT family, characterized by a wide seat shell and an elegant shape, introduces 2 new versions: the Lounge, wider and more comfortable, and the Mini, providing a more compact shell and new bases to open the use of this products to new environments.

Un'ampia scocca avvolgente racchiude la seduta in un morbido abbraccio.

Le cuciture ne definiscono e disegnano le linee morbide, dandole un aspetto elegante e versatile. Adatta a sale conferenza e aree relax di hotel e residenze. La famiglia di sedute Not, caratterizzate da un'ampia scocca avvolgente e dall'aspetto elegante e versatile, si amplia con due nuove versioni: la Lounge, dalle dimensioni più generose dove il comfort è in primo piano e la Mini, più compatta e con nuove basi che ne ampliano le possibilità di utilizzo a nuovi ambienti.

























VARIANTS
Varianti



NT 8090
W79 · D88 · H107

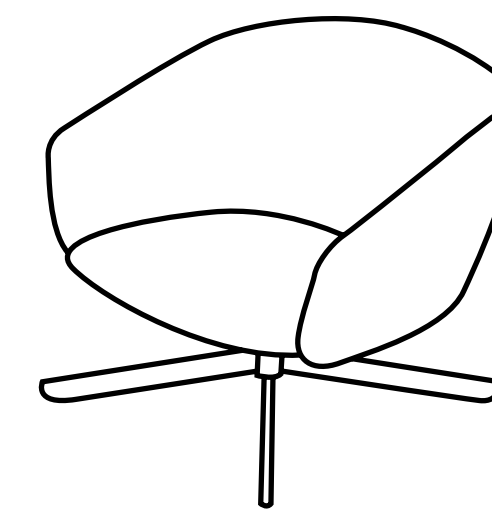

NT 7090
W79 · D78 · H70

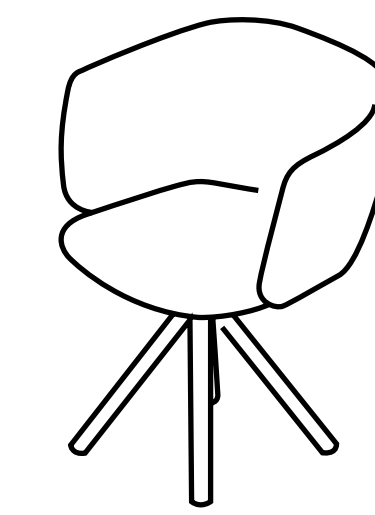

NT 5090
W64 · D54 · H78

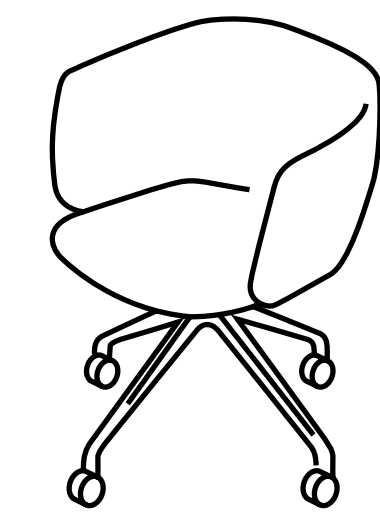

NT 509R
W64 · D58 · H78

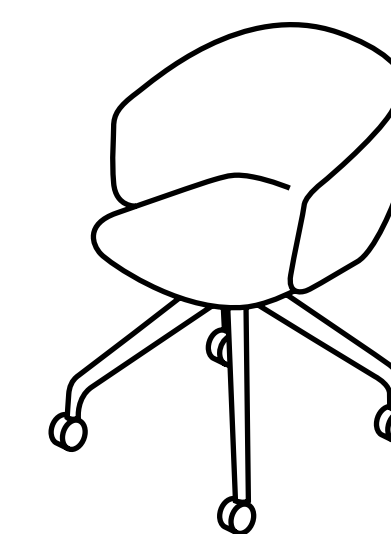

NT 409R
W56 · D58 · H76

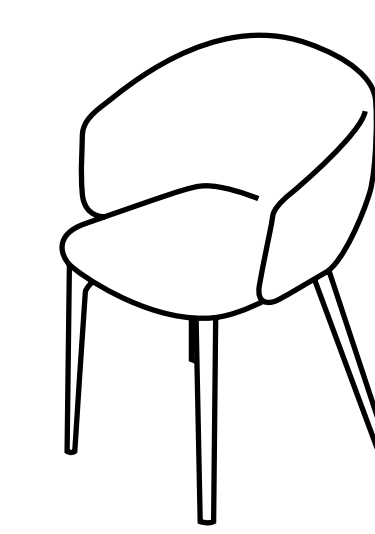

NT 4094
W56 · D58 · H76

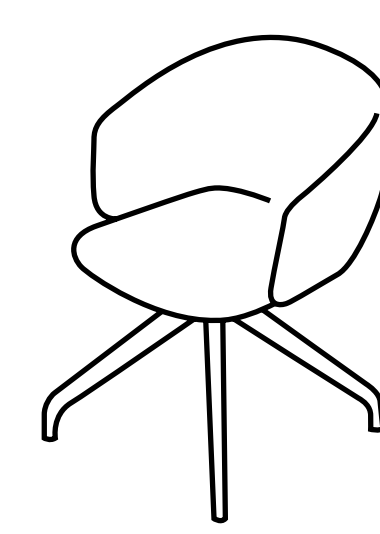

NT 4096
W56 · D58 · H76

true

True Design s.r.l.

Via Leonardo Da Vinci 2 - 35040 Sant'Elena (PD) Italy
Tel. +39 0429 692483 - info@truedesign.it - www.truedesign.it

Oracle

Orlandini Design



true

Oracle is a tactile modular meeting solution for open-plan spaces. The 'room within a room' booth provides an informal semi-private comfortable meeting space for activity based workers. With its versatile configurations it can be used as a quiet harbor to get away from your desk, or as a meeting/collaboration space for 2-6 occupants.

The high back design creates the sense of a mini-environment acting as a divider from the outside world, we have also added a porthole vision feature that enables you to discreetly see if the booth/pod is occupied.

Also included within the range are a number of work surfaces/desk tops (along with provision for power) that can be substituted for sofa elements to provide hot desking or touchdown spaces for transient workers.

Oracle è una soluzione modulare per spazi aperti. La soluzione "sala all'interno di una stanza" garantisce uno spazio per incontri informali semi-privati o un luogo confortevole per lo smart working. Con le sue configurazioni versatili può essere infatti utilizzato come un porto tranquillo per allontanarsi dalla scrivania o come spazio di incontro/lavoro per 2-6 persone.

Il design con schienale alto conferisce la sensazione di un mini-ambiente che funge da divisorio dal mondo esterno, con cui interagire discretamente attraverso la finestra posta sullo schienale.

La gamma è completata da una serie di piani scrivania completi di predisposizione per il cablaggio.



















VARIANTS
Varianti

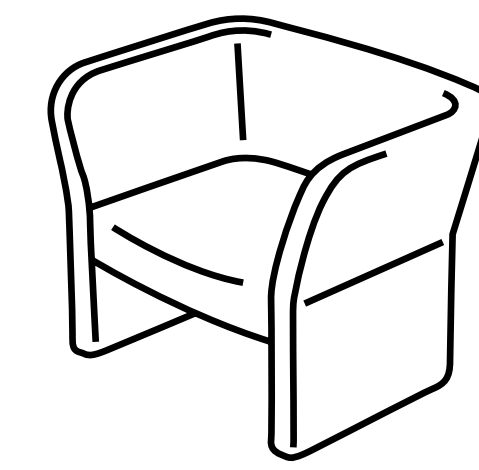

OR 1000
W94 · D72 · H77

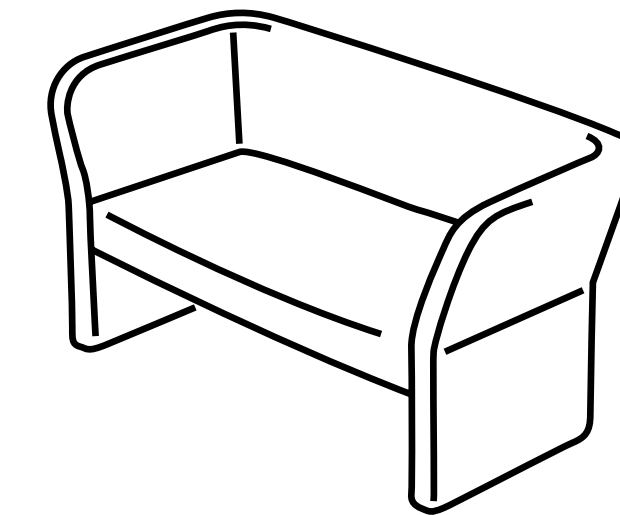

OR 2000
W144 · D72 · H77

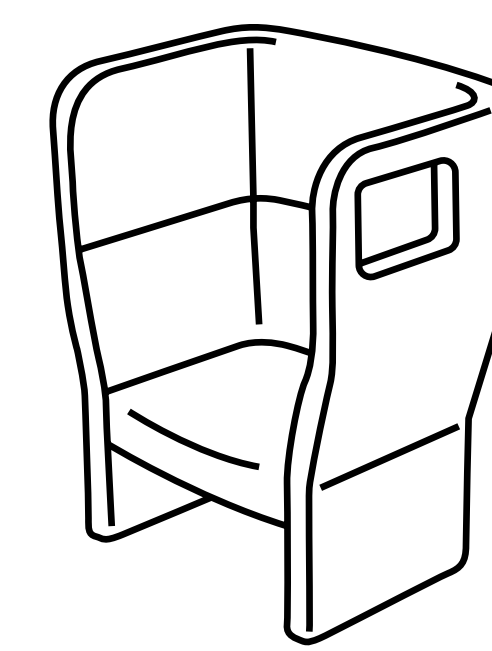

OR 100H
W94 · D72 · H123

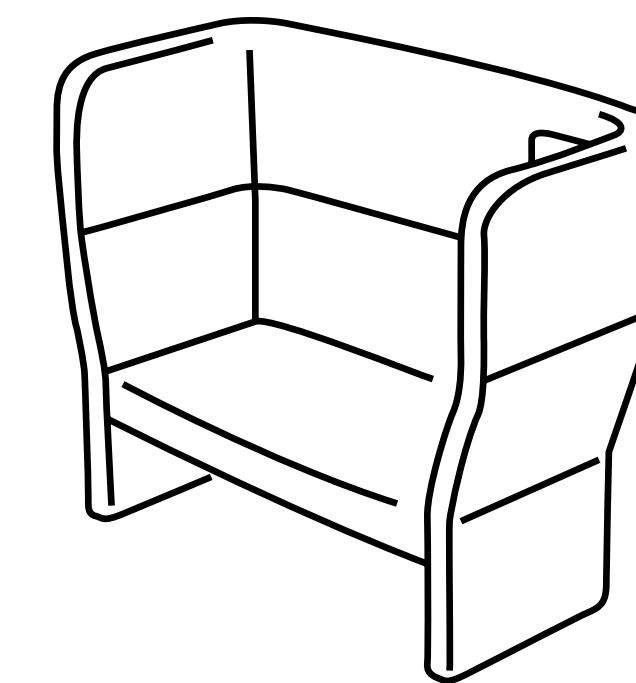

OR 200H
W144 · D72 · H123

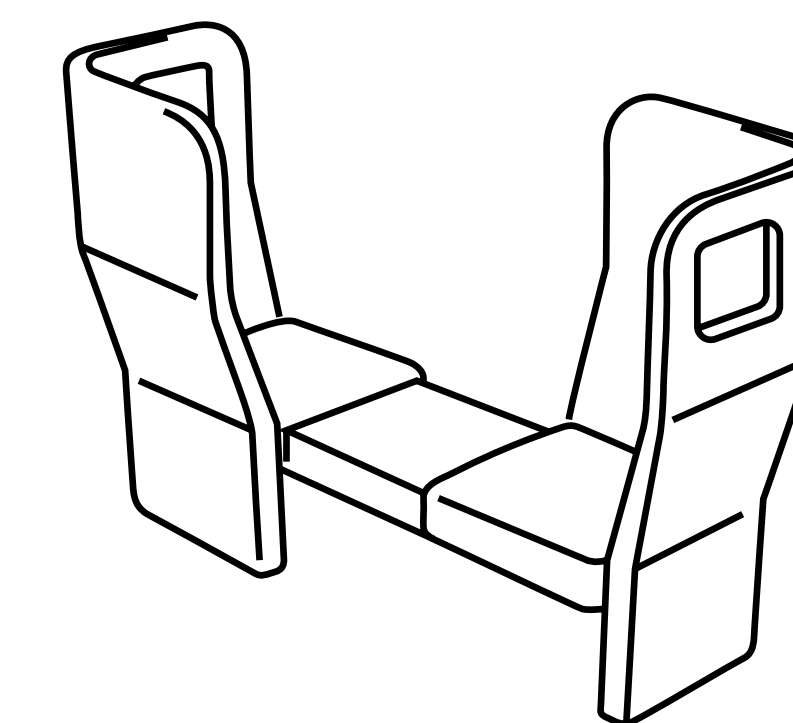

OR FF0H
W175 · D85 · H123

true

True Design s.r.l.

Via Leonardo Da Vinci 2 - 35040 Sant'Elena (PD) Italy
Tel. +39 0429 692483 - info@truedesign.it - www.truedesign.it

Pincettes

Luciano Dell'Orefice



true

Pincettes is a set of open dividers that offers many ways to isolate without encasing the users, respecting their habits when it's break time.

The construction logic is very simple and is designed to create small islands of peace within the work environment, where you can rest, read, chat or take a break in privacy. The module is composed by a thermoformed polyester fiber bearing with two layers of fabric, clamped inside a solid wood structure mounted on a pedestal of raw concrete. Pincettes, conceived as a design partition with acoustic purpose, easily adapts to any type of space, thanks also to the different conformations and the possible chromatic variables.

Pincettes è una collezione di pannelli divisori che garantiscono un elevato livello di privacy senza rinchiudere troppo l'utilizzatore, nel rispetto del rito dei momenti di pausa quotidiani. La logica costruttiva è molto semplice ed è adatta per ricavare piccole isole di pace all'interno dell'ambiente di lavoro, dove poter riposare, leggere, chiacchierare o fare una pausa in tutta intimità. Il modulo è composto da un cuscinetto di fibra di poliestere termoformato con due strati di tessuto, pinzato all'interno di una struttura in legno massello inserita su un piedistallo di cemento grezzo. Pincettes, pensato come divisorio di design con funzioni acustiche, si adatta con facilità ad ogni tipo di spazio, grazie anche alle diverse conformazioni e alle variabili cromatiche possibili.





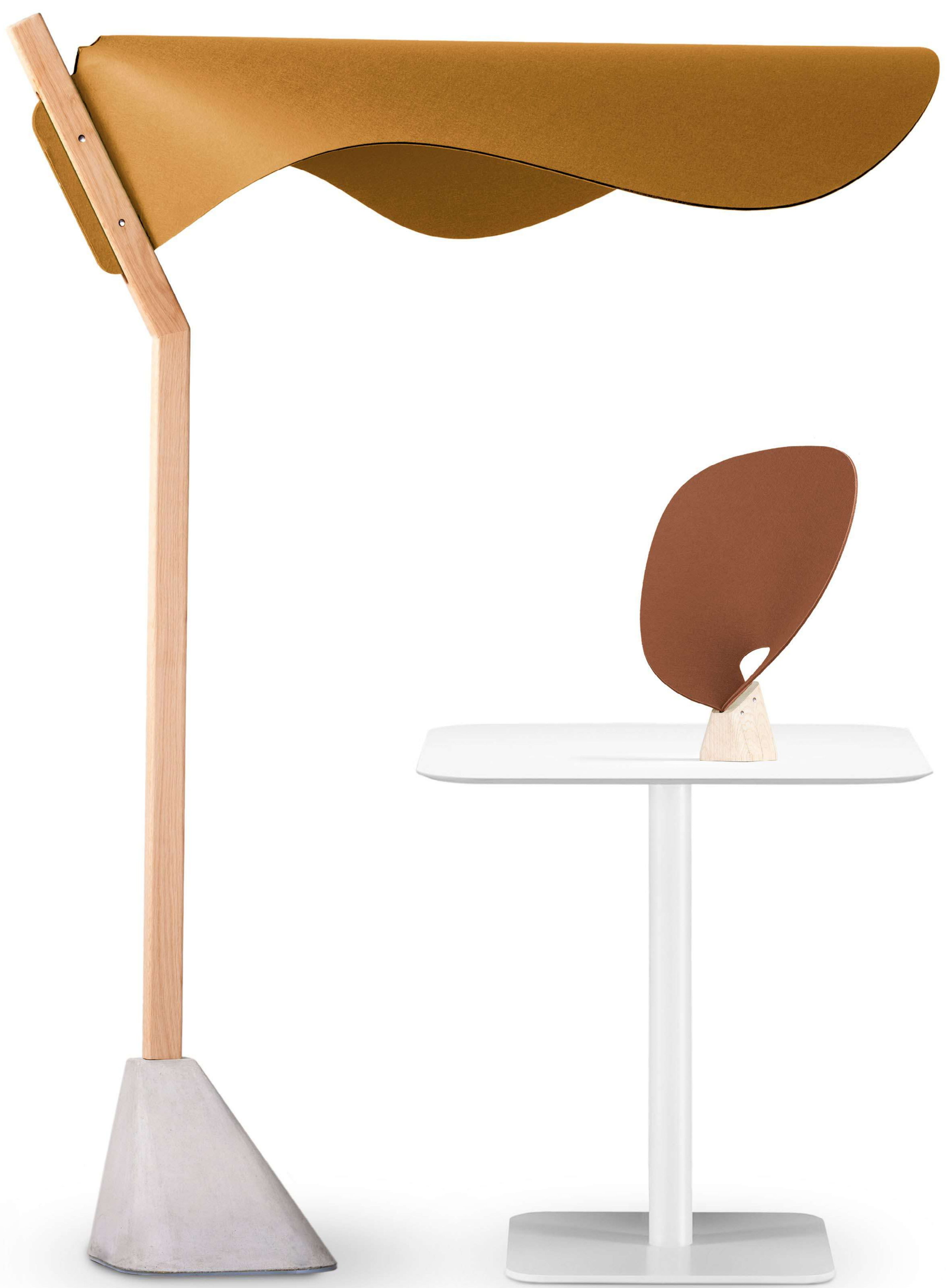





true









VARIANTS
Varianti

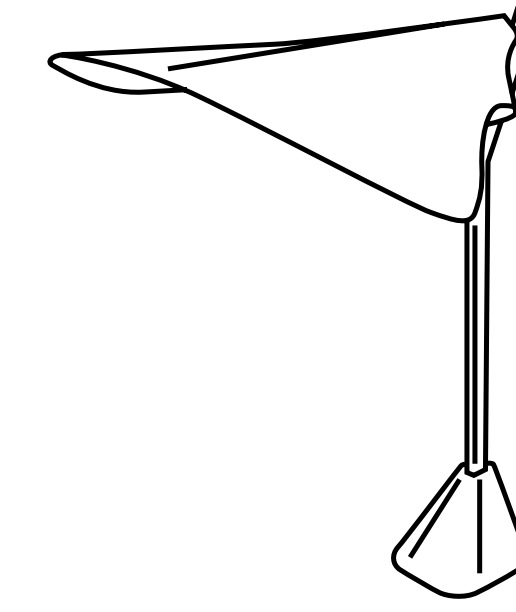

CAP
W160 · D155 · H210

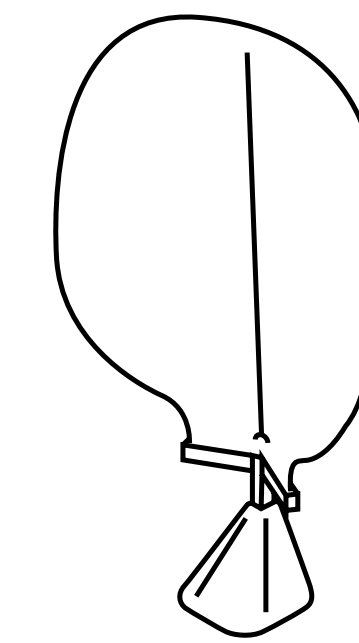

SHIELD
W160 · D39 · H191

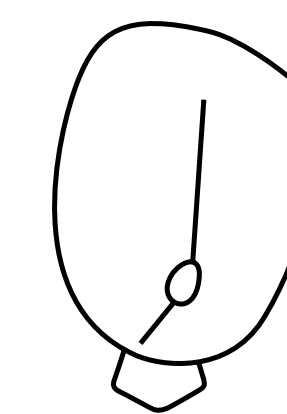

MASK
W45 · D15 · H50

true

True Design s.r.l.

Via Leonardo Da Vinci 2 - 35040 Sant'Elena (PD) Italy
Tel. +39 0429 692483 - info@truedesign.it - www.truedesign.it

SAKURA

Parisotto + Formenton



TECHNICAL FEATURES SPECIFICHE TECNICHE

Inner structure in multilayer beechwood, covered with variable density flexible foam padding. Solid beechwood legs.

Struttura interna in multistrato di faggio, imbottita con poliuretano espanso a densità differenziate. Telaio in legno massello. Gambe in legno massello di faggio.

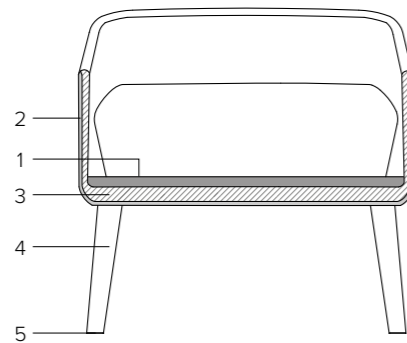

- 1 Upholstery
Rivestimento
- 2 High resistance foam
Poliuretano espanso indeformabile
- 3 Wood inner frame
Struttura interna in legno
- 4 4 legs solid wood structure
Telaio 4 gambe in legno massello
- 5 Felt pad
Piedino con feltro

COLORS AND MATERIALS COLORI E MATERIALI

WOOD / LEGNO



Standard finishing for wood is natural ash. Customized RAL or PANTONE colors are available upon request.

La finitura standard del legno è il frassino naturale. Su richiesta sono disponibili altre essenze e colorazioni customizzate su tinta RAL o PANTONE.

SK 4094 chair poltrona

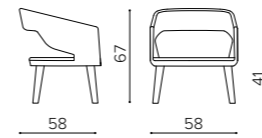

m 1,3 ☆ mq 2,5 📦 kg 11 🛠 mc 0,2

SK 1000 armchair poltrona

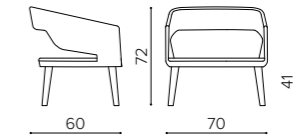

m 1,5 ☆ mq 2,8 📦 kg 13,5 🛠 mc 0,3

SK 2000 2 seater sofa divano 2 posti

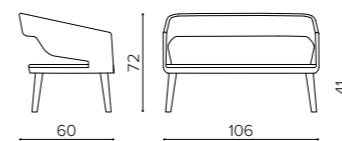

m 1,9 ☆ mq 3,8 📦 kg 18 🛠 mc 0,5

SK 3000 3 seater sofa divano 3 posti

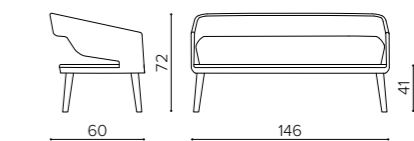

m 2,4 ☆ mq 5 📦 kg 23 🛠 mc 0,65

SK 200B 2 seater bench panca 2 posti



m 1,65 ☆ mq 3,1 📦 kg 20 🛠 mc 0,3

SK 300B 3 seater bench panca 3 posti



m 2,25 ☆ mq 4,5 📦 kg 24 🛠 mc 0,4

Slight

Christophe Bourban & Luciano Dell'Orefice



true





Thin as a leaf, the SLIGHT sofa collection takes the opposing view to the classic padded sofa. Like a little folded page, the soft body embraces you in different ways and comes out in several forms according to use requirements, both suitable for waiting areas such as domestic interiors.

Sottile come una foglia, la collezione di sedute SLIGHT prende il classico imbottito in contropiede. Come una pagina appena piegata, la scocca soffice vi abbraccia in modi diversi e si declina a seconda delle esigenze d'uso. Pensato sia per gli spazi d'attesa sia per gli ambienti domestici.



true











true





VARIANTS
Varianti

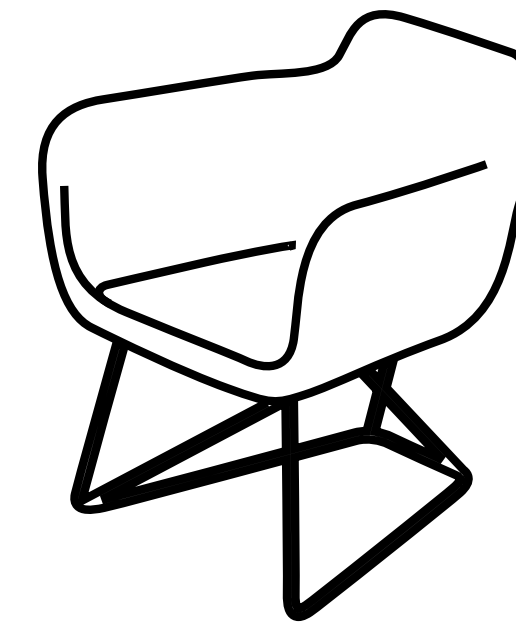

SL 1000
W68 · D60 · H83

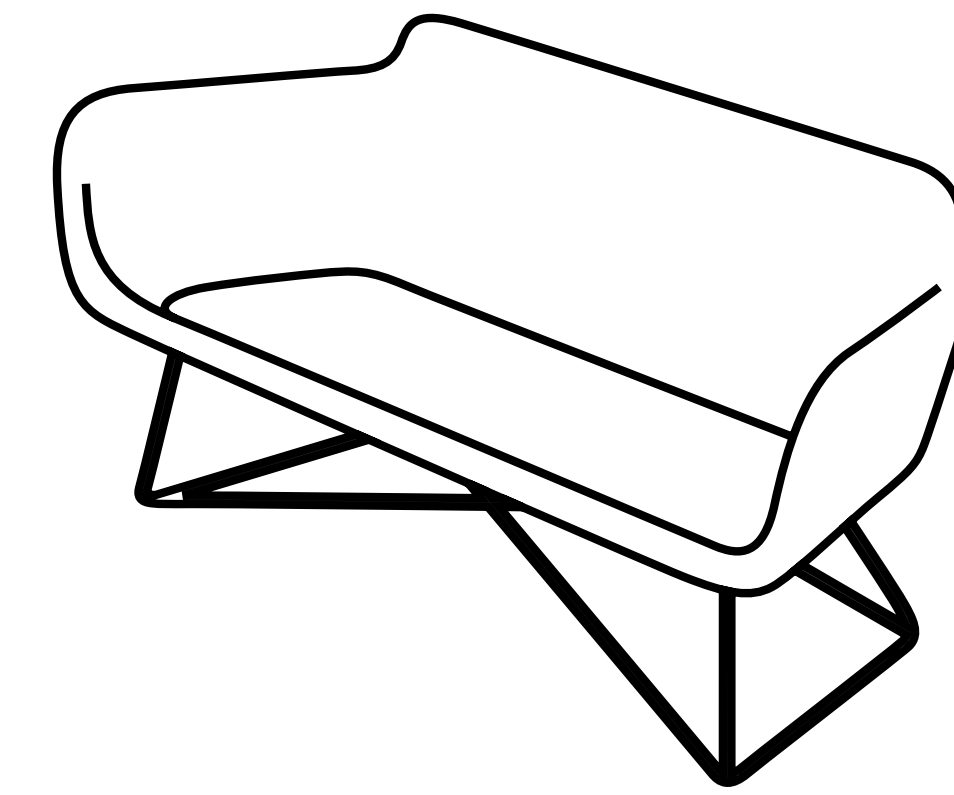

SL 2000
W180 · D68 · H83

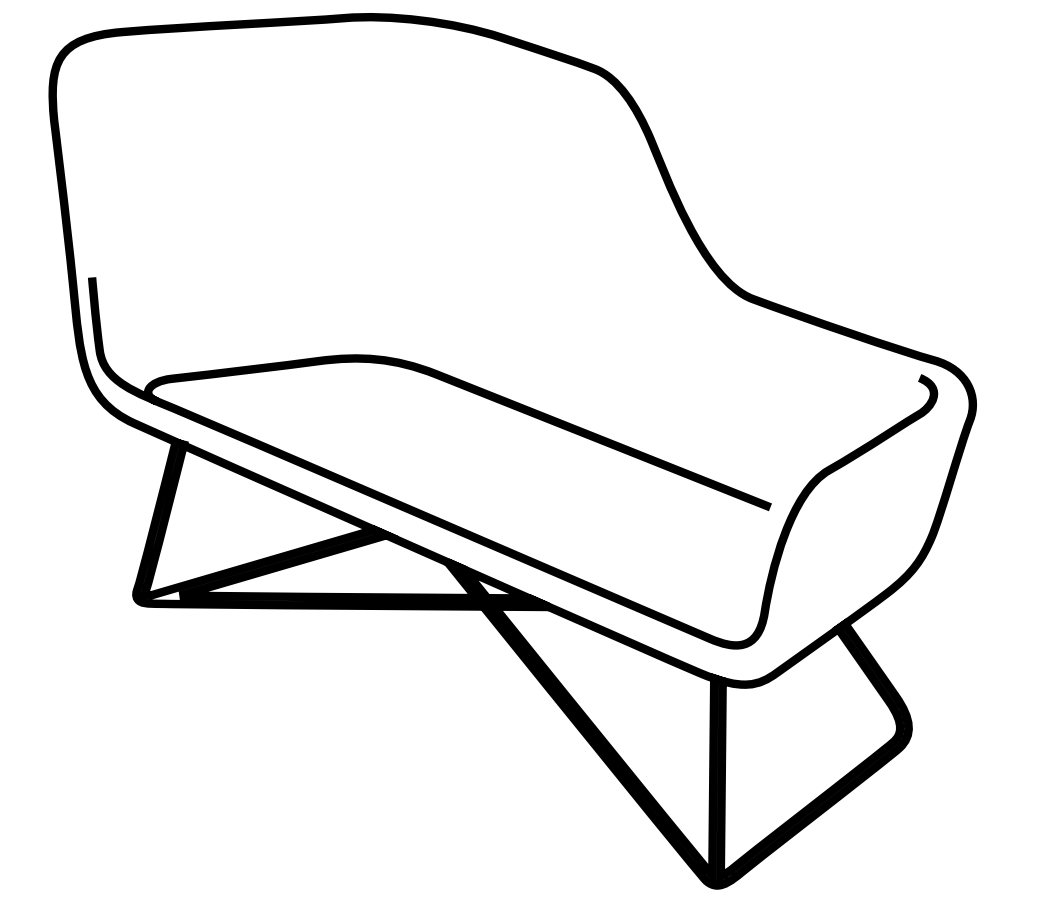

SL 5000
W180 · D68 · H98

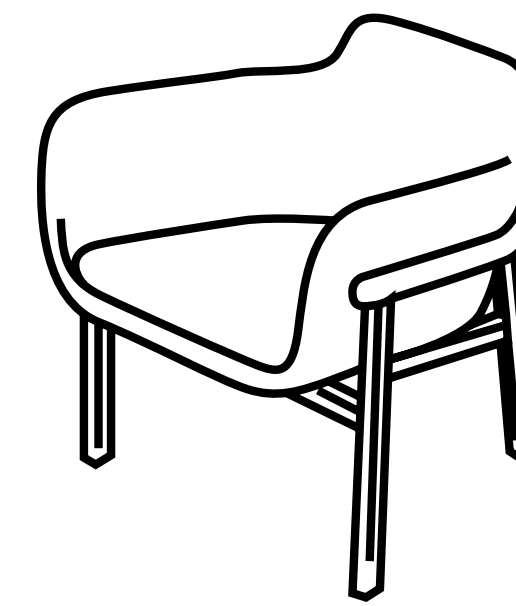

SL 100W
W78 · D62 · H75

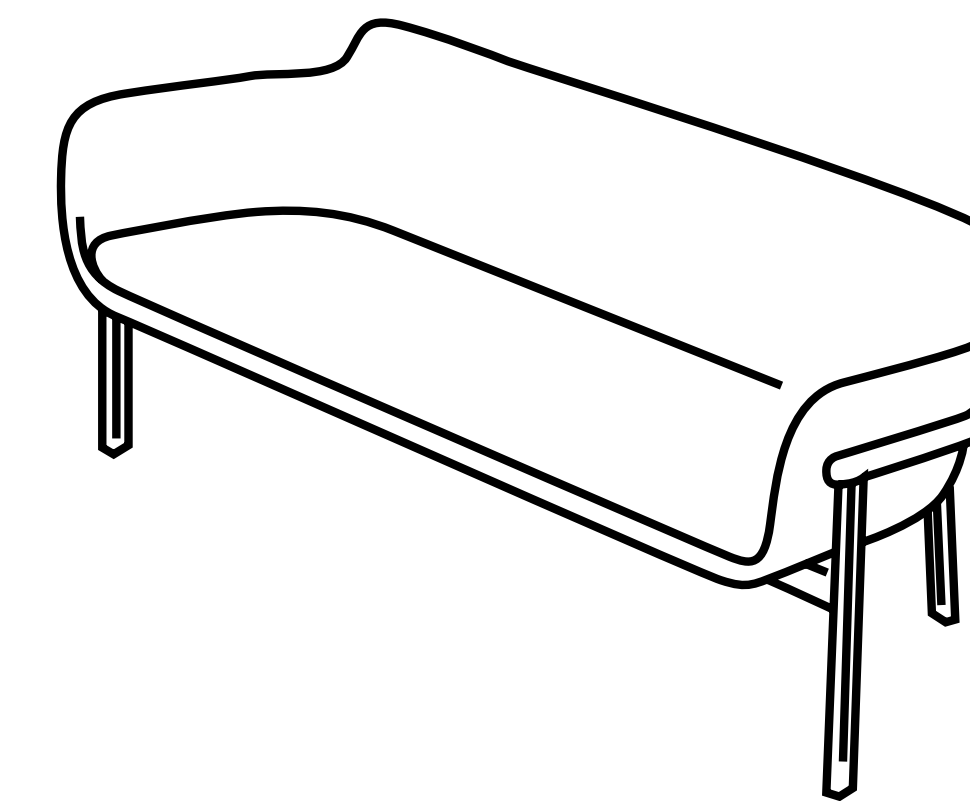

SL 200W
W180 · D62 · H75

true

True Design s.r.l.

Via Leonardo Da Vinci 2 - 35040 Sant'Elena (PD) Italy
Tel. +39 0429 692483 - info@truedesign.it - www.truedesign.it

Wing

Parisotto+Formenton



true

WING is a table created for working areas, but it can also fit inside a home-office or domestic environment. It is characterized by a wooden frame inspired by the sawhorse of the working tables, and the rounded shape of the top with its contemporary lines.

Defined by great flexibility, WING can be completed with acoustic panels, a brass reading lamp and wooden or metal trays that are installed on the large central channel through a magnetic fixing system. Power supply and cable management are allocated on the same central channel.

WING è un tavolo che nasce per gli ambienti di lavoro, ma può essere declinato in contesti di home-office o domestici. Si caratterizza per la struttura sottostante leggera, che trae ispirazione dai cavalletti dei tavoli da lavoro, e per il top dalle forme arrotondate “a saponetta” dalle linee molto contemporanee.

Dotato di grande flessibilità d'uso, si accompagna ad accessori come i pannelli divisorii imbottiti, la lampada centrale in ottone e i vassoi in legno e metallo che si inseriscono, grazie a un sistema di agganci magnetici, sul grande canale centrale adibito anche alla distribuzione elettrica e all'organizzazione cavi.









Central Channel

Canale Centrale

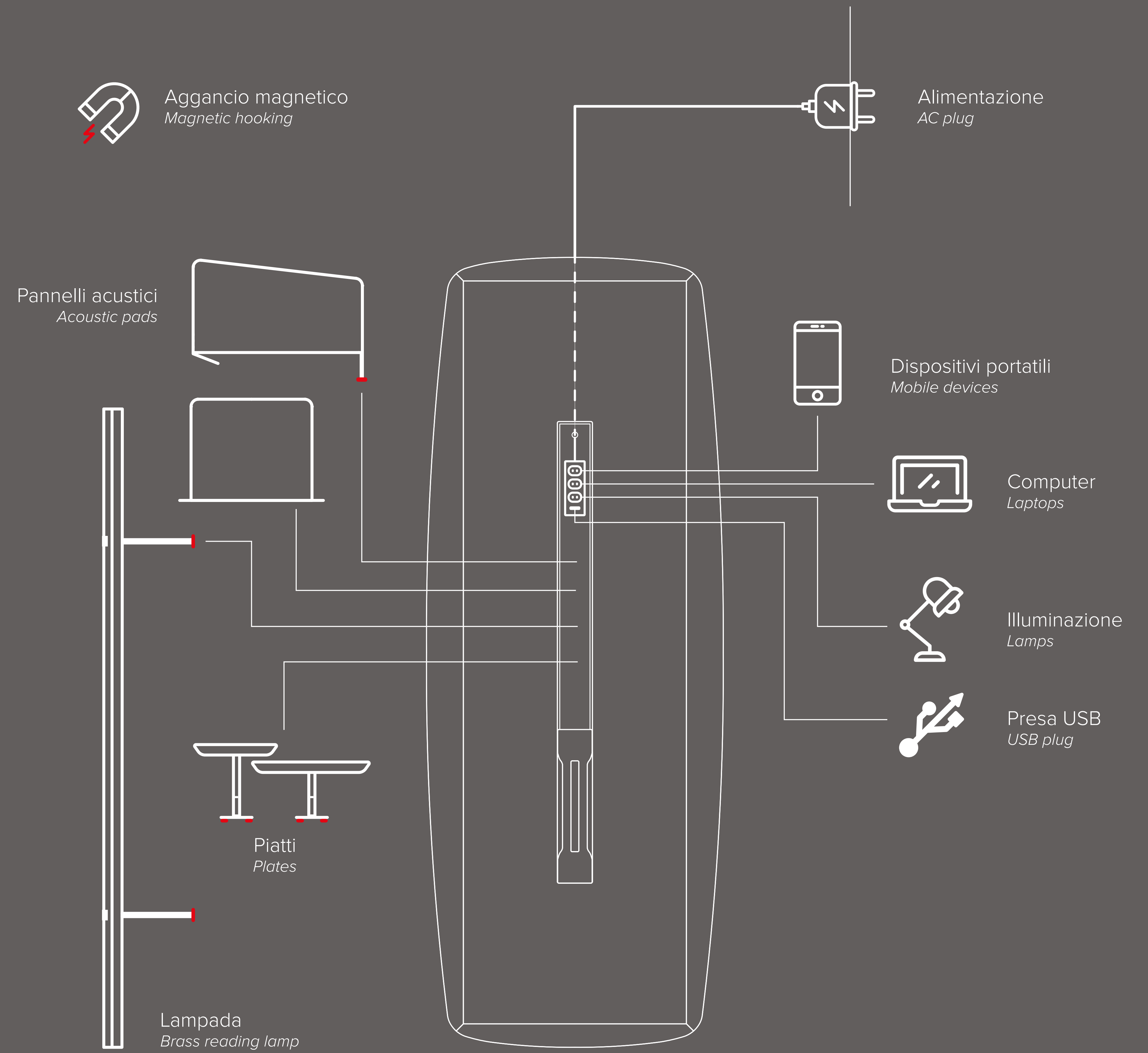



















true



VARIANTS
Varianti

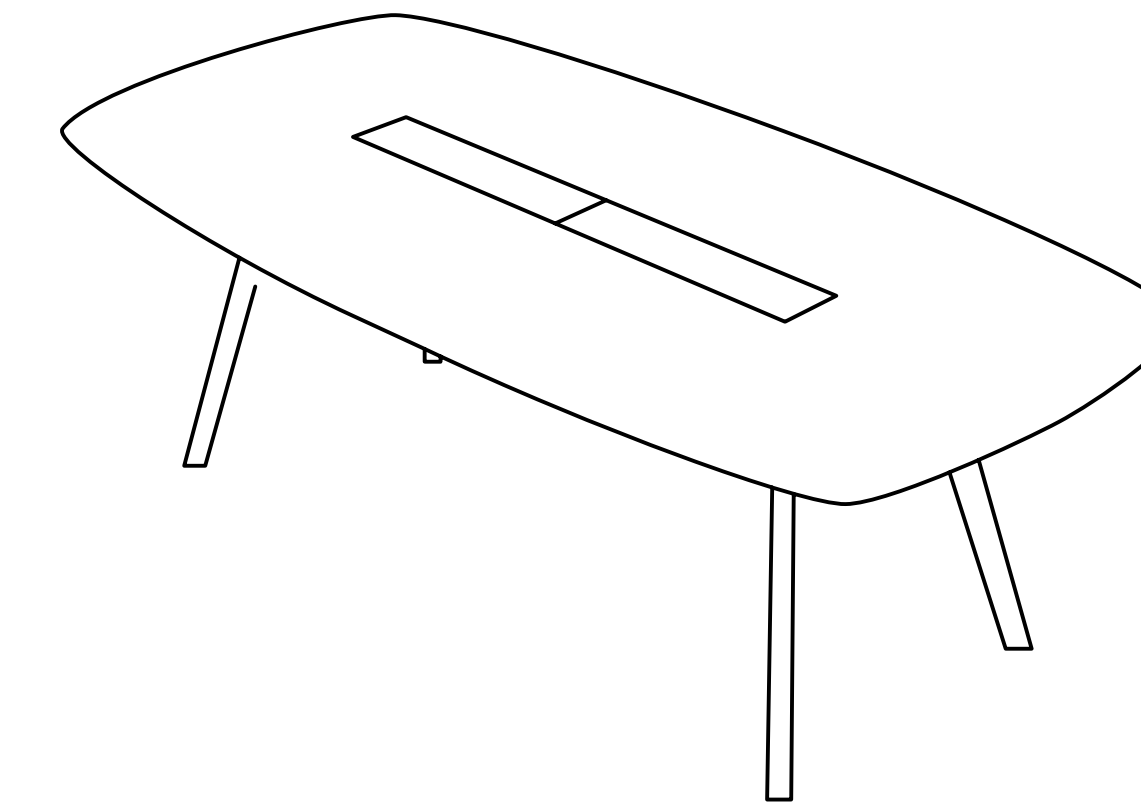

WI 220
W220 · D110 · H74

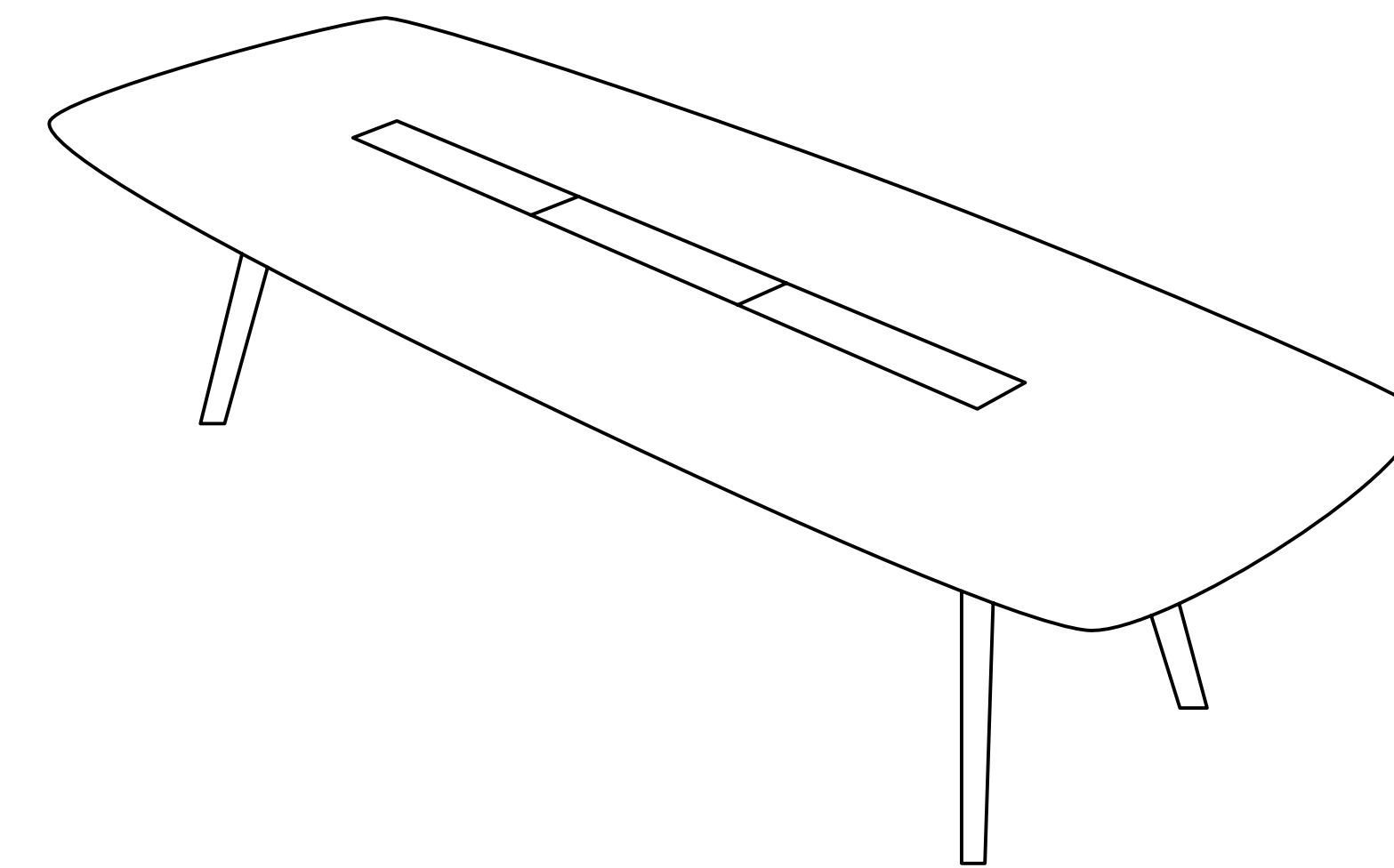

WI 320
W320 · D120 · H74

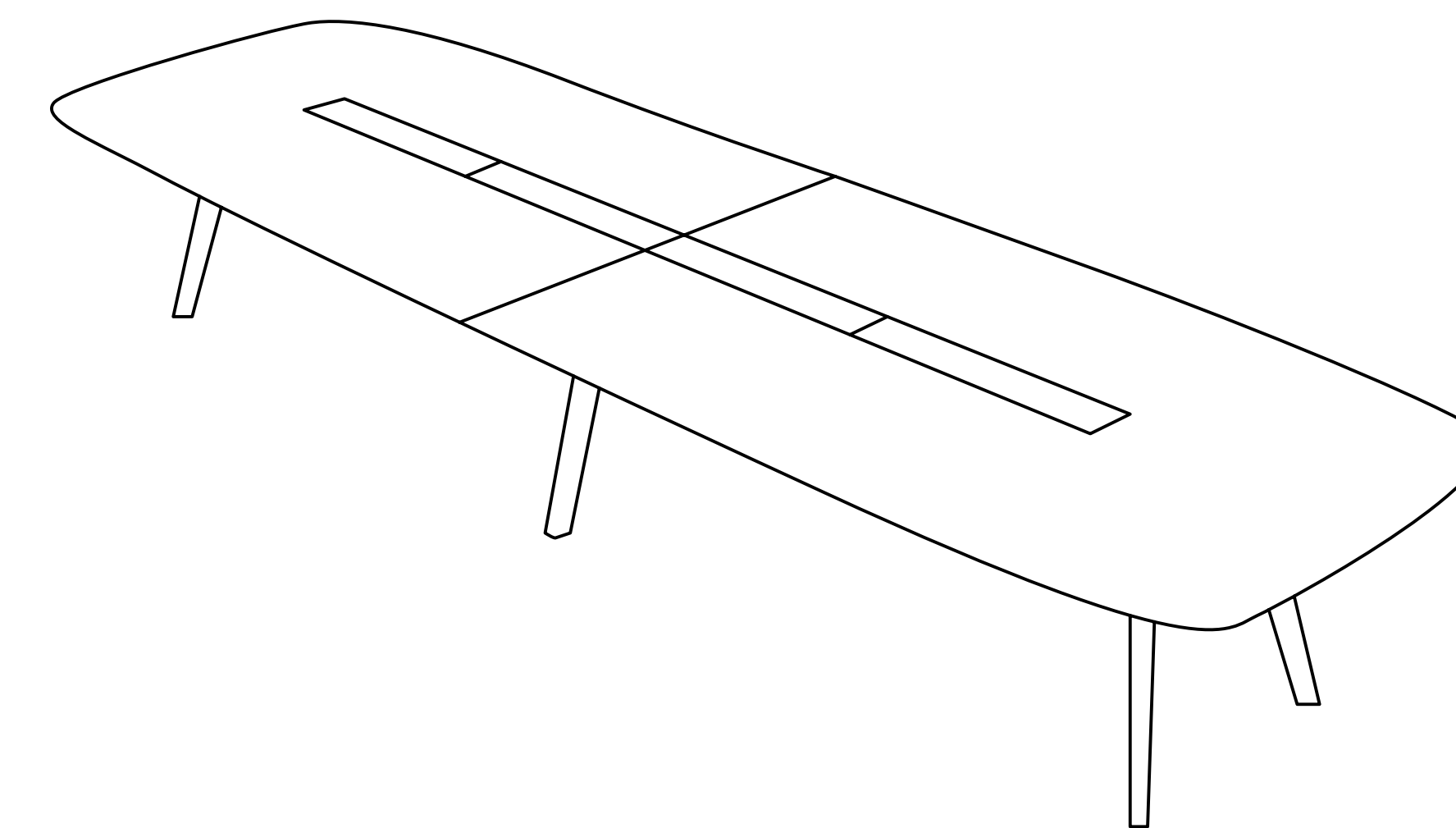

WI 450
W450 · D140 · H74

true

True Design s.r.l.

Via Leonardo Da Vinci 2 - 35040 Sant'Elena (PD) Italy
Tel. +39 0429 692483 - info@truedesign.it - www.truedesign.it